

OAK ST

Oak Flooring
2200 mm x 220 mm



OAK ST
Natural Limed [OS-1002]

OAK ST

FEATURES

Pre-finished matte lacquered planks.

>

Extra large plank format.

>

Multi-ply core construction.

>

Tongue and Groove joining profiles.

>

Fire and Slip Test certified.

www.wonderwoodfloors.com.au



OAK ST
White Smoked [OS-1123]



French Natural

OS-1001
Smooth Lacquer Surface



Natural Limed

OS-1002
Brushed Lacquer Surface



Narva

OS-1006
Handscraped Lacquer Surface



Helsinki

OS-1026
Brushed Lacquer Surface



Saddle Brown

OS-1121
Brushed Lacquer Surface



Smoky Oak

OS-1122
Brushed Lacquer Surface



White Smoked

OS-1123
Brushed Lacquer Surface



Monk Grey

OS-1124
Brushed Lacquer Surface

TECHNICAL SPECIFICATION

Timber Grade		ABCD
Dimension	Length	2200 mm
	Width	220 mm
	Thickness	15 mm
Bevel	Top Layer	4 mm
	Long-Sided	Micro Bevel Edges
Joining System	Short-Sided	Square Edges
		Tongue and Groove
Supplied	Box Size	2.904 m ² / 6 Panels
	Nesting	< 25% Random Short boards
Installation	Direct Stick	Yes
	Floating	Yes
Moisture Content		9-12%
Warranty - Wear	Domestic	25 Years
	Commercial	By Request



WONDERWOOD
www.wonderwoodfloors.com.au



COLORADO
Midnight Grey [CRD-1022]

OAK STAIR NOSE

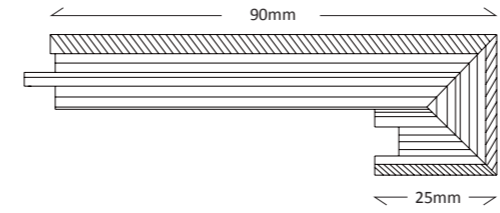

COLLECTION	OAK ST	COLORADO
Supplied Per Length	2.2 meter	1.9 meter
Material	Manufactured from pre-finished engineered timber	
Features	Square Nose Front	
	Available in all colours	

SKIRTING

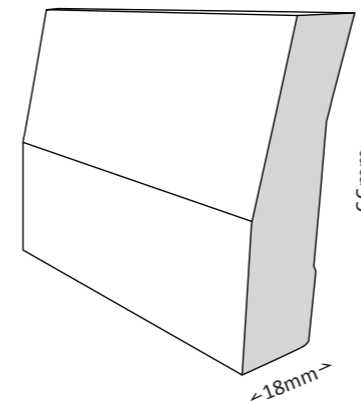
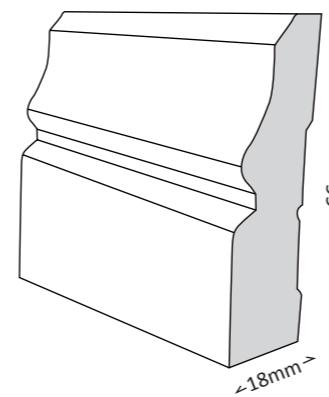
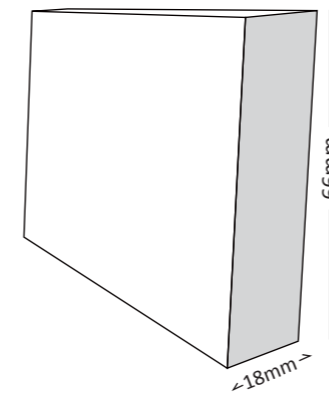

DAR		
Supplied Per Length	Length	2.7 meter
	Width	66 mm
	Thickness	18 mm
Material	Solid Pine	
Finish	Undercoat	

COLONIAL		
Supplied Per Length	Length	2.7 meter
	Width	66 mm
	Thickness	18 mm
Material	Solid Pine	
Finish	Undercoat	

HALF SPLAY		
Supplied Per Length	Length	2.7 meter
	Width	66 mm
	Thickness	18 mm
Material	Solid Pine	
Finish	Undercoat	

VARIATIONS AND FLOORING FACTS

Wonderwood Floors Products are made from natural materials. Individual pieces and batches may vary in colour, texture and naturally occurring features.

Reproduction in printing and photography are for guidance only. These give an indication of colour and are not necessarily representative of the overall effect or design.

When making your selection, please take care when selecting from a single sample, as this is only an indication.

In all jobs, the flooring products supplied will contain variation from board to board and job to job, and from the samples on display. The colour of your flooring may change over time with exposure to UV light.

Each flooring product continues to take up and release moisture during its life, depending on local conditions, environmental conditions and weather changes. Being aware of this and checking conditions is important before installation.

For a lasting floor product, it is essential to install your floating floor in accordance with Wonderwood's guidelines. Please read installation guides before proceeding with your flooring installation.



WONDERWOOD

www.wonderwoodfloors.com.au