



WONDERWOOD

www.wonderwoodfloors.com.au  
T: 02 9090 2810 | 02 9739 6565

# WONDERWOOD COLLECTION 2019/2020



INSPIRED BY NATURE, CRAFTED BY PASSION



**TERMS & CONDITIONS:** Colour and grain of product image in this brochure may differ from the actual product due to colour variation in the printing process. All product purchases are subject to Wonderwood Floors standard terms and conditions of sale. Please refer to our installation guideline, maintenance and warranty document for further clarification. Our products come with guarantees that cannot be excluded under the Australian Consumer Law. Consumers are entitled to a replacement or refund for a major failure and compensation for any other reasonably foreseeable loss or damage. Consumers are also entitled to have the goods repaired or replaced if good fail to be of acceptable quality. Please refer to our warranties on [www.wonderwoodfloors.com.au](http://www.wonderwoodfloors.com.au)



**Oak St** Timber Flooring  
**Colorado** Timber Flooring  
**Hydromate** Laminate Flooring  
**Hybrid** Flooring

# OAK ST

Oak Flooring  
2200 mm x 220 mm



OAK ST  
Natural Limed [OS-1002]

## OAK ST

### FEATURES

Pre-finished matte lacquered planks.

>

Extra large plank format.

>

Multi-ply core construction.

>

Tongue and Groove joining profiles.

>

Fire and Slip Test certified.

[www.wonderwoodfloors.com.au](http://www.wonderwoodfloors.com.au)



OAK ST  
White Smoked [OS-1123]



**French Natural**

OS-1001  
Smooth Lacquer Surface



**Natural Limed**

OS-1002  
Brushed Lacquer Surface



**Narva**

OS-1006  
Handscraped Lacquer Surface



**Helsinki**

OS-1026  
Brushed Lacquer Surface



**Saddle Brown**

OS-1121  
Brushed Lacquer Surface



**Smoky Oak**

OS-1122  
Brushed Lacquer Surface



**White Smoked**

OS-1123  
Brushed Lacquer Surface



**Monk Grey**

OS-1124  
Brushed Lacquer Surface

## TECHNICAL SPECIFICATION

Timber Grade		ABCD
Dimension	Length	2200 mm
	Width	220 mm
	Thickness	15 mm
	Top Layer	4 mm
Bevel	Long-Sided	Micro Bevel Edges
	Short-Sided	Square Edges
Joining System		Tongue and Groove
Supplied	Box Size	2.904 m <sup>2</sup> / 6 Panels
	Nesting	< 25% Random Short boards
Installation	Direct Stick	Yes
	Floating	Yes
Moisture Content		9-12%
Warranty - Wear	Domestic	25 Years
	Commercial	By Request



**WONDERWOOD**  
www.wonderwoodfloors.com.au

# COLORADO

Oak Flooring  
1900 mm x 190 mm



COLORADO  
Inky Grey [CRD-3002]

## COLORADO

### FEATURES

Pre-finished matte lacquered planks.

>

Selected Grade, solid oak top wear layer.

>

Three layered construction.

>

Tongue and Groove joining profiles.

>

Fire and Slip Test certified.

[www.wonderwoodfloors.com.au](http://www.wonderwoodfloors.com.au)



COLORADO  
Brown Leaf [CRD-3004]



**Midnight Grey**

CRD-1022  
Brushed Lacquer Surface

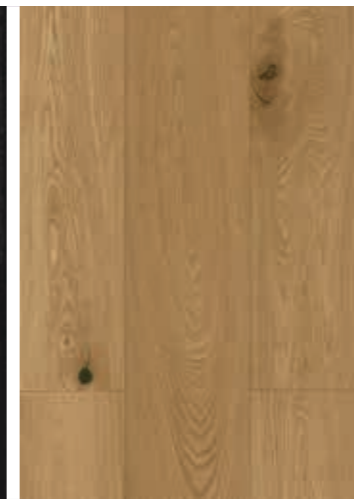

**Light Neutral**

CRD-3001  
Brushed Lacquer Surface



**Inky Grey**

CRD-3002  
Brushed Lacquer Surface

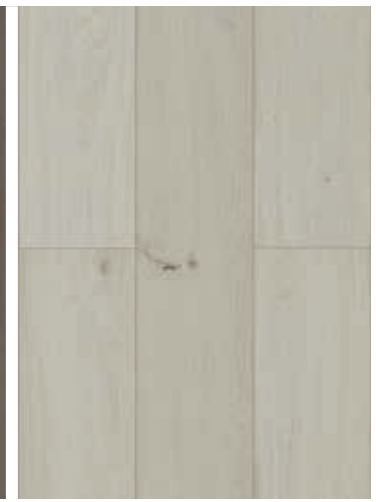

**Casper White**

CRD-3003  
Brushed Lacquer Surface



**Brown Leaf**

CRD-3004  
Brushed Lacquer Surface

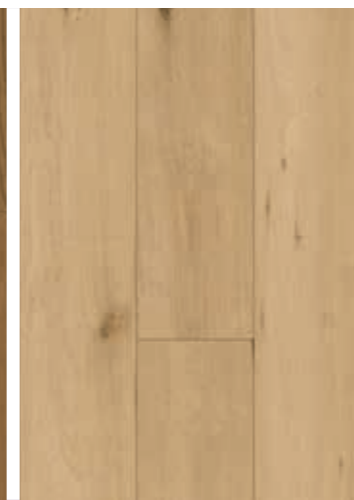

**Tinge Clay**

CRD-3005  
Brushed Lacquer Surface

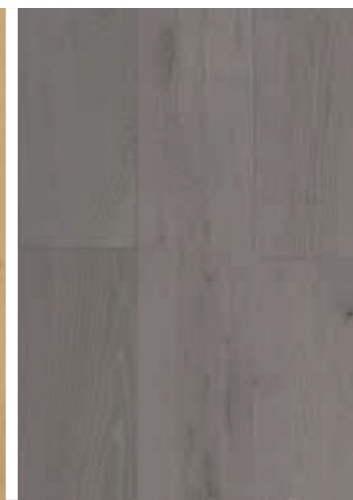

**Weathered Grey**

CRD-3006  
Brushed Lacquer Surface



**Lime White**

CRD-3007  
Brushed Lacquer Surface

## TECHNICAL SPECIFICATION

Timber Grade	ABC	
Dimension	Length	1900 mm
	Width	190 mm
	Thickness	15 mm
	Top Layer	4 mm
Bevel	4-Sided Micro Bevel Edges	
Joining System	Tongue and Groove	
Supplied	Box Size	2.888 m <sup>2</sup> / 8 Panels
	Nesting	< 15% Random Short boards
Installation	Direct Stick	Yes
	Floating	Yes
Moisture Content	8-12%	
Warranty - Wear	Domestic	25 Years
	Commercial	By Request



WONDERWOOD  
www.wonderwoodfloors.com.au

# HYDROMATE

Laminate Flooring  
2250 mm x 195 mm



## LUXE HYDROMATE FLOORING

### More water resistant than ever

Your flooring needs to stand up to the wear and tear of everyday life.

The new Hydromate range has been created with a tighter clicking system and a protective aluminium oxide layer.

This clever design prevents liquid from finding its way under the surface of your floor.

### Choose Hydromate for:

A stunning visual finish.

Superior quality.

48 hour water resistance.

Reduced risk of swelling and distortion.

*Other floorboards are instantly susceptible to damage from water and other liquids. While Hydromate is not 100% waterproof, it provides better protection against everyday liquid spills than any other products.*

[www.wonderwoodfloors.com.au](http://www.wonderwoodfloors.com.au)



HYDROMATE  
Snowy Oak [HM-21965]



<b>Country Oak</b> HM-21963 Matte Embossed Surface	<b>Snowy Oak</b> HM-21965 Matte Embossed Surface	<b>Bianco</b> HM-21975 Matte Embossed Surface	<b>Blackbutt</b> HM-21986 Matte Embossed Surface	<b>Paloma</b> HM-21990 Matte Embossed Surface
--	--	---	--	---



<b>Winteridge</b> HM-21992 Matte Embossed Surface	<b>Bravado</b> HM-60221 Matte Embossed Surface	<b>Jasper</b> HM-60227 Matte Embossed Surface	<b>Dapple Grey</b> HM-60229 Matte Embossed Surface	<b>Spotted Gum</b> HM-60243 Matte Embossed Surface
---	--	---	--	--

## TECHNICAL SPECIFICATION

Abrasion Resistance	Certified AC4	
Dimension	Length	2250 mm
	Width	195 mm
	Thickness	12 mm
Bevel	4 Sided Micro Bevel Edges	
Joining System	Licensed Click System	
Supplied	Box Size	2.2 m <sup>2</sup> / 5 Panels
	Weight	25 kg
Formaldehyde Emission	< E1	
Slip Resistance	P2	
Fire Test	CHF Value	6.1 Kw/ m <sup>2</sup>
	Smoke Value	4%.min
AS 4266.8:2004 – 24hr Thickness Swell: Maximum 9%	0.10%	



WONDERWOOD  
www.wonderwoodfloors.com.au

# HYBRID

## Flooring

1540 mm x 182 mm



HYBRID

QLD Spotted Gum [HYB-91102]

# HYBRID

## FEATURES

100% Waterproof.

>

1.5mm, 6-star attached acoustic underlay.

>

Embossed textured surface.

>

Easy to install and low maintenance.

>

Durable, stain and scratch resistant.

>

Lays over almost any pre-existing floor surface.\*

*\*Subject to Wonderwood's installation guidelines and Australian standards, including appropriate expansion gaps and correct subfloor preparation.*

[www.wonderwoodfloors.com.au](http://www.wonderwoodfloors.com.au)





HYBRID  
Kandos Grey [HYB-91105]



**Blackbutt**

HYB-91101  
Matte Embossed Surface



**QLD Spotted Gum**

HYB-91102  
Matte Embossed Surface



**Copeland**

HYB-91103  
Matte Embossed Surface



**Kandos Grey**

HYB-91105  
Matte Embossed Surface



**Flannel Grey**

HYB-91106  
Matte Embossed Surface



**Bone Beige**

HYB-91107  
Matte Embossed Surface

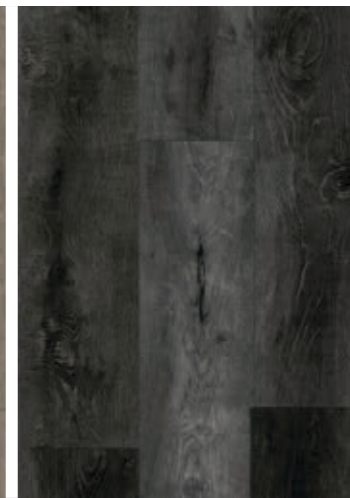

**Junee Reef**

HYB-91108  
Matte Embossed Surface



**Warm Smoke**

HYB-91109  
Matte Embossed Surface

## TECHNICAL SPECIFICATION

Wear Layer		UV Coating
	Length	1540 mm
	Width	182 mm
Dimension	Total Thickness	6.5 mm
	Wear Layer Thickness	0.5 mm
	Underlay Thickness	1.5 mm
Bevel		4-Sided Micro Bevel Edges
Joining System		Licensed Click System
Supplied	Box Size	2.243 m <sup>2</sup> / 8 Panels
	Weight	23.35 kg
	L'nTw	40
Impact Sound Reduction (AS ISO 717.2 – 2004)	FIIC	64
	AAAC	6 Star

To view our full testing report please request by email or visit [www.wonderwoodfloors.com.au](http://www.wonderwoodfloors.com.au)



WONDERWOOD  
[www.wonderwoodfloors.com.au](http://www.wonderwoodfloors.com.au)



COLORADO  
Midnight Grey [CRD-1022]

## OAK STAIR NOSE

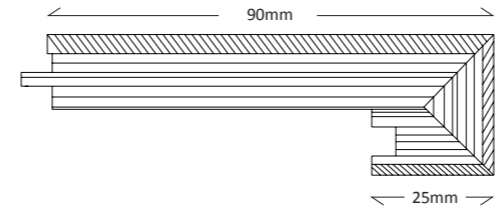

COLLECTION	OAK ST	COLORADO
Supplied Per Length	2.2 meter	1.9 meter
Material	Manufactured from pre-finished engineered timber	
Features	Square Nose Front	
	Available in all colours	

## SKIRTING

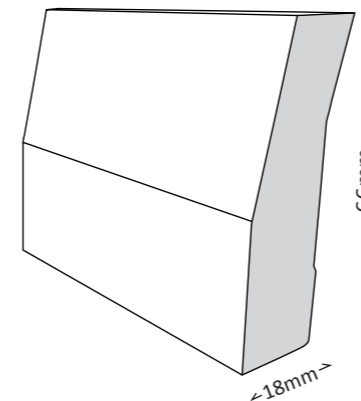
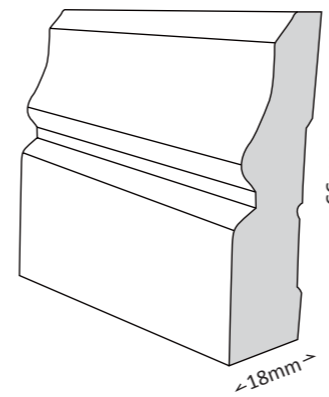
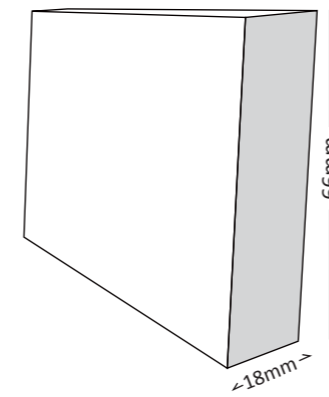

DAR		
Supplied Per Length	Length	2.7 meter
	Width	66 mm
	Thickness	18 mm
Material	Solid Pine	
Finish	Undercoat	

COLONIAL		
Supplied Per Length	Length	2.7 meter
	Width	66 mm
	Thickness	18 mm
Material	Solid Pine	
Finish	Undercoat	

HALF SPLAY		
Supplied Per Length	Length	2.7 meter
	Width	66 mm
	Thickness	18 mm
Material	Solid Pine	
Finish	Undercoat	

# FINISHING PROFILES

## Laminate / Hybrid



HYDROMATE  
Dapple Grey [HM-60229]

### SCOTIA

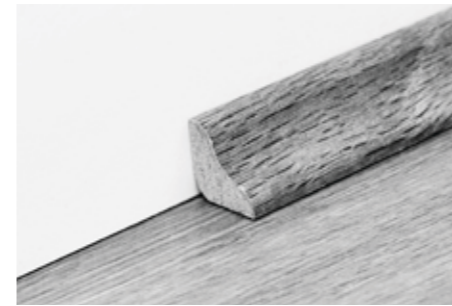

### CARPET REDUCER

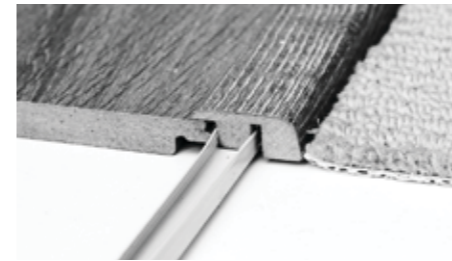

### REDUCER

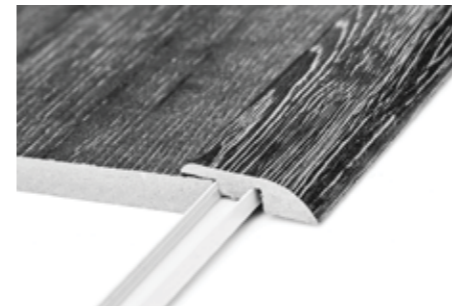

### T-MOULDING



### STAIR NOSE



	LAMINATE	HYBRID
Finish	Matched Color	Embossed and Matched Color
Material	HDF	HYBRID
Length	2.4 meter	2.4 meter
Dimension	28 x 15 mm	28 x 15 mm

	LAMINATE	HYBRID
Finish	Matched Color	Embossed and Matched Color
Material	HDF	HYBRID
Length	2.4 meter	2.4 meter
Dimension	35 x 15 mm	35 x 10 mm

	LAMINATE	HYBRID
Finish	Matched Color	Embossed and Matched Color
Material	HDF	HYBRID
Length	2.4 meter	2.4 meter
Dimension	45 x 15 mm	45 x 10 mm

	LAMINATE	HYBRID
Finish	Matched Color	Embossed and Matched Color
Material	HDF	HYBRID
Length	2.4 meter	2.4 meter
Dimension	28 x 15 mm	46 x 8 mm

	LAMINATE	HYBRID
Finish	Matched Color	Embossed and Matched Color
Material	HDF	HYBRID
Length	2.4 meter	2.4 meter
Dimension	115 x 24 mm	115 x 25 mm

Stair finishing should not be used for commercial applications

# VARIATIONS AND FLOORING FACTS

---

**Wonderwood Floors Products are made from natural materials. Individual pieces and batches may vary in colour, texture and naturally occurring features.**

Reproduction in printing and photography are for guidance only. These give an indication of colour and are not necessarily representative of the overall effect or design.

When making your selection, please take care when selecting from a single sample, as this is only an indication.

In all jobs, the flooring products supplied will contain variation from board to board and job to job, and from the samples on display. The colour of your flooring may change over time with exposure to UV light.

Each flooring product continues to take up and release moisture during its life, depending on local conditions, environmental conditions and weather changes. Being aware of this and checking conditions is important before installation.

For a lasting floor product, it is essential to install your floating floor in accordance with Wonderwood's guidelines. Please read installation guides before proceeding with your flooring installation.

---



WONDERWOOD

[www.wonderwoodfloors.com.au](http://www.wonderwoodfloors.com.au)