

Laminate Floors

Installation & Maintenance Guideline

General

Wonderwood Laminate Flooring is designed to be installed as a floated floor. Please inspect each board in optimal lighting for visual defect and locking system is proper functioning before and during installation. Products are considered of acceptable quality and structure once installed, do not install if in doubt.

Heavy and bulky objects, such as island bench, should not be placed on floating floors, Wonderwood Laminate Flooring must be cut in and installed around such objects. 8% to 10% of wastage floors is recommended to cover any sorting, trimming or visual selection during installation.

Sample, reproductions in printing and photography are only for guidance; they provide a colour indication but are not necessarily representative of the overall effect or design. Please be cautious when making your selection from a single sample, reproductions in printing and photography, as these are only an indication.

Preparation

1. Locality and Installation Environment

Seasonal relative temperature, humidity levels and variations in the installation area, as well as the projected average floor moisture content in that area, must be evaluated. Generally, lamination flooring may shrink more in dry environments and expand more in humid environments. In the event of extreme climatic conditions, product distortion is to be expected.

The condition of the flooring may be impacted by the internal environment of the building, such as the heating and cooling systems and the prospective effect of the large glassed windows, must be evaluated.

Following conditions should be considered before, during and after the installation,

- Floor surface temperature min. 15°C
- Ambient air temperature in between 18-24°C
- Relative humidity 40-60%

2. Handling & Storage and Inspection Of Boards

Please ensure the condition of the products before and during installation, the floorings with visible defects (scratches, dimple and cracks, etc.) that have been cut or installed are excluded from the general condition of warranty. Despite strict quality control, floorings may have been damaged, for example, during transportation. Do not install any damaged flooring.

Floors must be stored cool, shaded and dry, never be stored outside under direct sunlight or rain, on a cement floor, in a garage or in any damp conditions. Always store the packs flat and never lay the packs against a wall.

It is essential to allow at least 48 hours for floorboards acclimate in their original, unopened packaging in the installation area. When the temperature and humidity conditions in some areas exceed the conditions mentioned above in Preparation – section 1. Locality and Installation Environment, please make sure to allow Wonderwood Laminate Flooring to acclimate in their original, unopened packaging in the installation area for at least one week.

To avoid moisture accumulation on the laminate flooring, never open the packs until the day of installation. Before and during installation, each floor must be inspected to ensure that the quality is acceptable. Once installed, it will be deemed acceptable by the customer and no claims for any surface defects will be accepted. Wonderwood will take no further responsibility.

3. Subfloors

Subfloor is the structural element that the flooring is attached which included concrete subfloor or timber and sheet subfloor. All subfloors must be evaluated for factors that may have an impact on the installation, ongoing performance and appearance of the floor. Subfloor must be thoroughly even, dry, clean and solid. Ventilation requirements must be in accordance with the National Construction Code (NCC) of enclosed subfloor spaces. Before proceeding, any areas of concern must be addressed by the appropriate party.

3.1 Subfloor Flatness

Subfloor must be ground and levelled to the flatness acceptance required for the flooring system and products used, uneven subfloor can cause the locking system to fail, induce hollow and drummy sound after installation, resulting in early deterioration and failure of the floor. Please follow the subfloor levelness standard for Wonderwood Laminate Flooring that listed below,

Wonderwood Laminate Flooring subfloor flatness standard: Not to exceed 2mm in any 1m² in all direction

ATFA Laminate Flooring subfloor flatness standard: Not to exceed 2mm under a 1.0 meter straight edge

ATFA levelness of floor in the new buildings provided to a flooring contractor: Not to exceed 4mm in 2 meter.

Timber and sheet subfloor, particleboard and plywood subfloor should be sanded (gently and thinly) on all sides and surface to ensure flatness.

Carpet, carpet staples and underlay, glue residue and existing floating floor must be removed to ensure proper installation.

3.2 Subfloor Moisture Content

Please ensure the subfloor is clean and dry before installation and remain dry after installation. A moisture meter is required to be equipped to read the moisture level. Moisture content level requirements are listed below.

Concrete – Concrete subfloor must be dry, clean and crackfree. A dry concrete subfloor index indicates on the moisture meter reading is up to 2% and in concrete relative humidity (RH) of up to 75%, as if the concrete subfloor had been previously covered, acceptable value of moisture meter reading is up to 3.5% and in concrete relative humidity (RH) of up to 80%. (Index figured refer to ATFA)

Timber and Sheet - Timber and sheet subfloor must be dry, clean and free of loose or grinding planks or joists, nails and screws. A dry timber and sheet subfloor index indicates on the moisture meter reading is up to 8% and if the timber and sheet subfloor had been previously covered, acceptable value or moisture meter reading is up to 10%. Relative humidity (RH) is not exceeded 95%.

Any reading higher than the figure above required further investigation into possible moisture sources and may require more moisture protection or further actions to meet the requirement prior installation, fail to meet the moisture content requirement may void Wonderwood Laminate Flooring warranty.

4. Moisture Barrier; Underlay & Acoustic Underlay

To provide moisture protection from Wonderwood Laminate Flooring, moisture barrier and underlay with acoustic sound absorbing/acoustic underlay (particularly important for multilevel apartments) is required to be installed prior any installation of laminate flooring. A recognized acoustic underlay must be installed with a polyethylene moisture vapor barrier underneath, or use a 2 in 1 foam underlay that comes with a moisture vapor barrier built-in. Both should be installed on a dry subfloor with moisture proof tape. Joins and seams between plastic sheets must be sufficiently overlapped and taped to prevent moisture vapor leakage from underneath. Moisture barrier should be at least 200mm and run at least 100mm up vertical the skirting boards on perimeter walls and trim back after installation to avoid moisture ingress.

5. Expansion Allowance

The generally used calculation formula of expansion across the width is 1.5mm expansion for every 1m floor width and length. For Wonderwood Laminate Flooring, allow at least 10-15mm expansion gaps on each edge or fixed vertical perimeter surface. The expansion gap allowance is also determined by the temperature variations in the installation building, the climatic conditions of the installation area will as well give an impact about the expansion gap allowance. In areas with low or average humidity, the gap allowance might be 10-12mm; and in areas with high humidity, the gap allowance might need to be 12-15mm.

Extra expansion gap allowance will be required to compartmentalize a larger room area. Room to room expansion breaks at doorway or rooms area exceeding 8m x 8m is recommended.

Well undercut any door jamb, frame or threshold/sill at doorways or transitions, remove any spacers or wedges from the room and install Wonderwood skirting boards, scotia or other finishing trims for covering the perimeter expansion gap. Never fix finishing trims directly to floor or compromise the expansion gap, fixing should be done only to the wall. Silicone or caulking compound must not be used as it restricts movement and prevents the floor from floating.

Inadequate expansion gaps (including but not only in doorways) and under trims, can cause a floor to buckle, peak, cup or separate, may resulting in floor failure.

6. Floor Heating System:

Wonderwood Laminate Flooring is not compatible for any floor heating system. Any type of floor heating may void Wonderwood Laminate Flooring warranty.

Installation

The subfloor or underfloor must be completely even, dry, clean and solid. To ensure proper installation, carpet staples or glue residue must be removed and the floor must be clean.

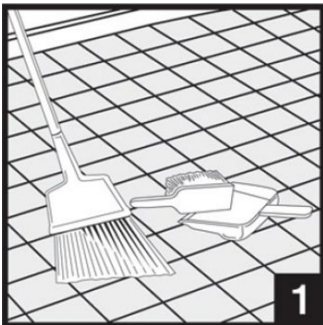

Check for evenness before proceeding with any installation: Hammer a nail into the centre of the floor. Tie a string to the nail and press it against the floor. Pull the string all the way to the farthest corner of the room and examine the floor at eye level for any gaps between the string and the floor. Move the string around the perimeter of the room, noting any gaps larger than 2mm. Any floor unevenness greater than 2mm per 1m² must be sanded down or filled in with an appropriate filler.

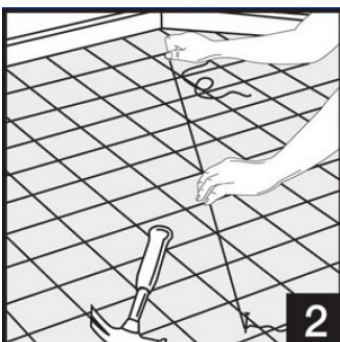

Moisture problems of the floor must be thoroughly checked. Any moisture issues must be resolved before installation.

THIS PRODUCT IS NOT SUITABLE FOR DAMP ROOMS SUCH AS BATHROOMS, SAUNAS, ROOMS WITH DAMP CONCRETE, ROOMS WITH FLOOR DRAINS OR ROOMS THAT COULD POTENTIALLY FLOOD.

New concrete subflooring must cure for at least 60 days before installation. For installation on concrete floors or any floors over a crawl space a moisture vapor barrier must be laid down first. A recognized 4 mil polyethylene should be used. Run the polyethylene 10cm up the walls and overlap at the seams. Tape seams.

Foam underlay is required for all Wonderwood Laminate Flooring installation. The foam underlay should be applied in the same direction as the laminate panels. The underlay should be butted together with no overlap. Tape seams together.

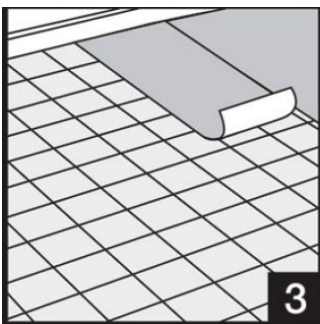

The tongue on the long side of the panels facing the wall needed to be removed, from the appropriate amount of panels for the first row. Cut the tongue and ensure that the decorative surface of the laminate is well when install finished trim. Score the tongue several times with a utility knife until it snaps off easily.

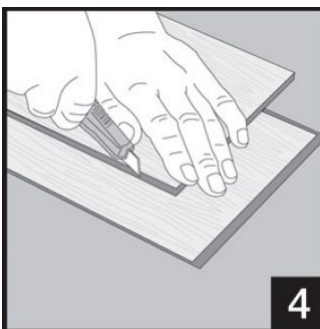

Begin with a corner by placing the first panel with its trimmed side facing the wall. Use spacers along each wall to maintain a 10-15mm expansion space between the wall and the flooring.

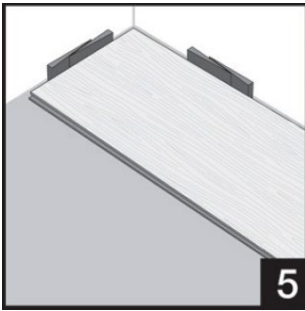

REMEMBER THAT THIS IS PRODUCT IS PRIMARILY WOOD AND REQUIRES ROOM TO EXPAND AND CONTRACT. PLEASE NEVER ATTACH THE FLOOR TO ANY SURFACE.

Using a rubber mallet and a tapping block to attach the ends of the panels. Carefully align the edges.

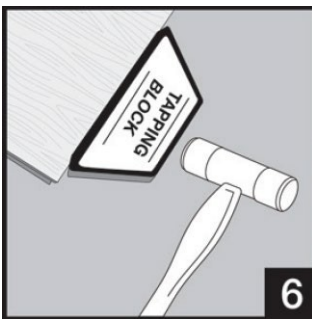

Continue along the wall until the last panel. To fit the last panel, mark off the excess and saw off with a handsaw cut when the decorative side is up. When using a jig or circular saw cut, please make sure the decorative side is down to avoid chipping. Tap the last panel into place with a pull bar.

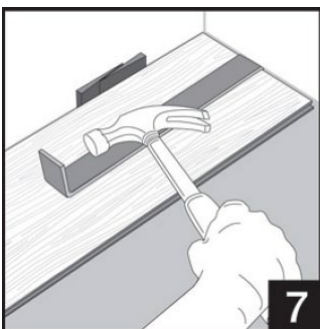

Start the next row with the offcut piece from the previous row to stagger the pattern. Piece should be at least 20cm long with a joint offset of at least 40cm. To attach the panels, tilt the panel slightly upwards to about 15-25°, when lowered the plank, it will click into place with light pressure. Ensure that any gaps are as small as possible. Continue locking each panel into place, ensuring a straight and tight fit beginning with the long side first and then tapping the short side into place. Always use a rubber mallet and tapping block instead of striking the floor directly, which could damage the locking system.

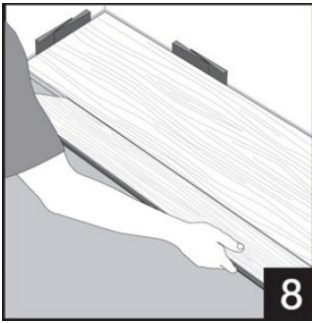

To fit the last row, place a panel on top of the previous row. With the tongue to the wall, place another panel upside down on the one to be measured and use it as a ruler. Do not forget to allow room for spacers.

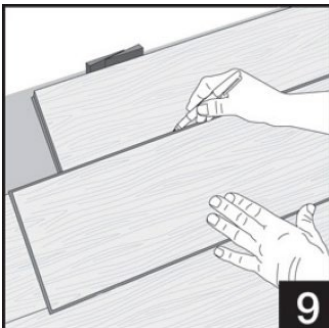

Cut the panel and tap it into place with the pull bar.

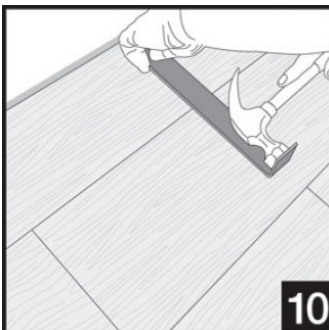

Expansion space is always needed for areas, such as door frame and heating vents. First, trim the panel to the proper length. Then place the cut panel next to the actual position and use a ruler to measure and mark the areas to be cut out. Cut out the marked points and allow the necessary expansion distance on each side.

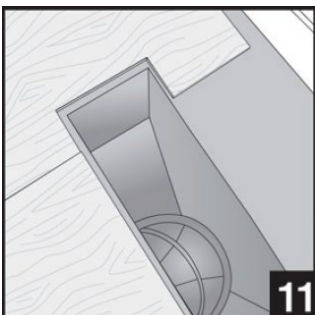

Trim door frames by turning a panel upside down as a height measurement and using a handsaw to cut away the necessary height so that panels slide easily underneath the frame.

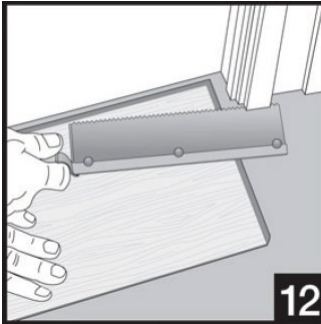

After removing spacers from all expansion gaps, install finishing molding around the room.

Please select Wonderwood finishing molding based on the situation and the instruction below.

FINISHING MOLDING



reducer molding



landing/stair molding



T-molding



quarter round molding



U-track

Reducer Molding/Carpet Reducer: When the adjoining surface is lower than the laminate flooring or when the flooring meets carpet. Place the U-track 7mm between the edge of the flooring. Screw, nail or glue down the track directly to the subfloor, then insert the reducing strip into the track.

T-molding: When two level surfaces meet in doorways or for expansion joints. If the area is wide than 8m, an expansion joint is needed. Expansion joints with using T-molding can be placed in any inconspicuous place. Place the U-track 7mm between the edge of the flooring. Screw, nail or glue down the track directly to the subfloor, then insert the T-molding into the track.

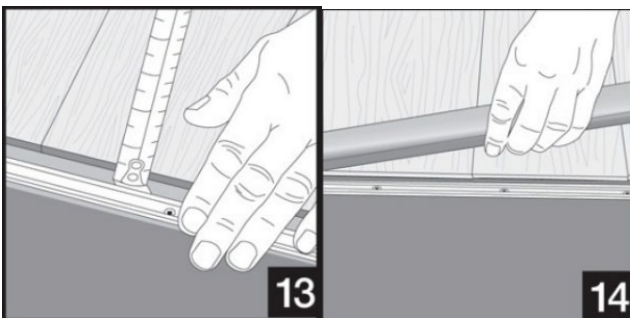

Landing/stair molding: To finish flooring on landings or stair edges. For safety and stability, moldings must be glued and screwed to the subfloor. Countersunk screws should be covered with color fill.

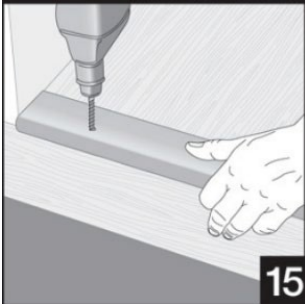

Quarter round molding/Scotia: To finish the perimeter of the room. Quarter round molding or scotia must be nailed directly into the baseboard.

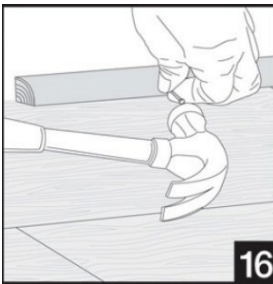

Never attach finishing molding/trims directly to the floor and make sure any attachment does not compromise or affect any expansion gaps.

Care & Maintenance

Wonderwood Laminate Flooring is a low maintenance product, simply take some precautions and follow the regular cleaning and maintenance routines, your floor will stay wonderful from time to time.

1. Routine Maintenance

- Place a mat in front of all entrances/kitchen sinks to keep dirt, sand, grit and water off the floor.
- Vacuum, mop or sweep the floor on a regular basis, recommend once a week or more if needed, to remove dirt, dust, adhesive after installation, grit, water, etc. that can scratch or harm the floor.
- The mop must be cloth-covered, damp mop must be with pH neutral floor cleaner. Do not spray or pour excess amount of water or floor cleaner on the floor or remain on the floor, excess amount of water or floor cleaner may damage the floor.

- Do not use soap based, oil based, ammonia based, wax based or abrasive floor cleaner, acrylic finishes, bleach or acidic material (e.g. vinegar) on the floor which can leave a slippery and dull finish that is extremely hard to remove or damage and abrasive the floor.
- Never use steam mop, steel wool or wax and polish on the floor.
- The vacuum must be brushed head, dust filter or floor head attached. Do not use vacuum with hard head attachment or with a beater bar on the brush roll.
- Always soak or wipe up any spills (water, wine, pet urine, etc.) on the floor with a dry or clean cloth promptly; most spills can be easily wiped up with the immediate handle. However, some liquids or materials containing strong pigments/dyes may still migrate permanent stains to the floor, such as grease, oil, dyes material, waxes, ball point pens, marker pens, pet accidents, some renovation or construction products (e.g. tar), or foods and beverages such as mustard, curry, wine, coffee or tea, etc. Do not leave spills unattended for an extended period of time.
- Stubborn stains can be removed by spot cleaning using damp cloth or sponge with concentrate pH neutral floor cleaner (e.g. pH neutral Bona Wood Floor Cleaner) or stain remover designed specifically for laminate floor.
- Place drip pans beneath indoor plants to prevent water leakage.
- Maintain the indoor temperature above 5°C (preferably between 18°C – 30°C).
- Ensure the subfloor temperature always within the temperature range specified in this installation and maintenance guide. Do not install heating system under laminate floor.

2. Preventative(Prevention) Maintenance

2.1. Prevent scratches and dents

- Please use rug or mat in any heavy traffic area or underneath any large furniture/appliances/item (avoid using rug or mat with rubber backs/vinyl backs and non-breathable rug or mat that may induce moisture absorption).
- Trim your pet's nails to avoid unnecessary scratches and scuffs.
- Always stick soft pads, floor protectors or furniture sliders to the base of all furniture in contact with the floor and replace them as necessary periodically. Move rugs/mats or large furniture/appliances/items periodically to allow the natural aging for the laminate floor. Pick up heavy furniture or appliances when moving across the floor instead of sliding.
- Avoid walking on the floor while wearing shoes with heel taps, sport cleats, stiletto heels or in need of repair bottom may cause significant damage to the floor.
- Avoid any sharp objects protruding across the floor such as rocks, nails or gravel.
- Never allow extremely hot material contaminate the floor, such as cigarettes, matches or ashes which may result in permanent damage to the floor.

2.2.Prevent discoloration

- Avoid direct sunlight from the floor, exposure to sunlight/UV stimulates oxidation and aging of the floor and lead to colour shade variation. Curtains and UV resistant film are recommended (particularly important for building with large glassed windows).
- Avoid using any rubber products on the floor, such as rugs/mats with rubber/vinyl backs, soft pads/furniture sliders with rubber/vinyl backs, rubber soles shoes/slippers, furniture/cabinet with rubber wheels, etc. Contact with rubber may discolour the floor.
- Avoid using any rugs/mats that are made with non-breathable material that may induce moisture trapping/accumulation that may over humid and discolour the floor.

2.3.Prevent expansion and shrinkage

- Never steam mop or wet mop the floor with water or any other liquid floor cleaner. Exceed amount of water or liquid may lead to unnecessarily expansion of the floor.
- Always wipe up spills promptly with damp cloth.
- Keep the indoor humidity level between 35%-55%. Please use a humidifier in a dry climate or a dehumidifier in a humid and wet climate to maintain the ideal humidity level.
- Direct sunlight (especially building with large glassed window) can raise the temperature of the floor surface over 70° C and dramatically drop to the temperature under 5° C, the rapid and extreme temperature change can caused the floor gapping with expansion and shrinkage. Please protect the floor with indoor temperature control.

3. Fix dings and scratches

- Minor scratches, marks or dings on the floor surface can be repaired by using a staining pen of the matching colour.
- Slightly deeper scratches or marks can be diminished by using a combination of matching coloured putty and stains.
- Before any actual repairing, please do a test sample with the compatible repair kit on a less visible area or a wastage plank.
- Replacement planks are recommend for severe or very deep scratches or dings.
- Laminate floors cannot be sanded.

4. Common Characteristics of Laminate Floors

Wonderwood Laminate Flooring are a stable product, due to laminate floors nature, planks can still expand and shrink due to extreme or rapid changes in climatic conditions and resulting in small gaps between planks. Gaps should not be greater than 0.15% of the floor's length/width. This is a normal characteristic of laminate floors and not considered as a manufacturing defect.